

REV	DATE	DESIGNER	DESCRIPTION	ENG APPR.	MFG APPR.
A	23-3-2016	NME	First release	MST	

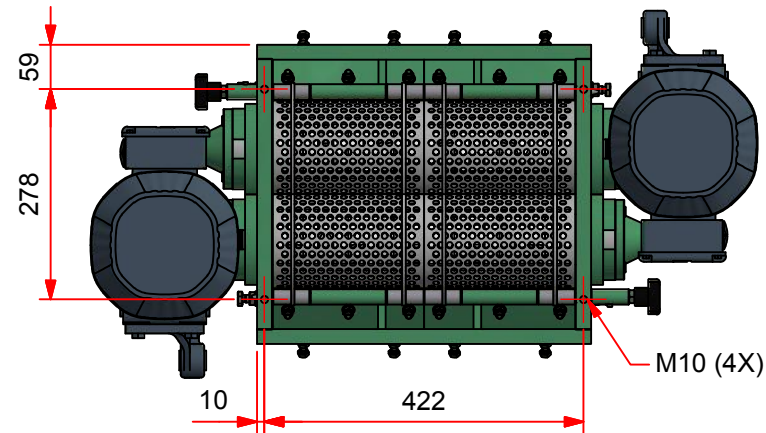
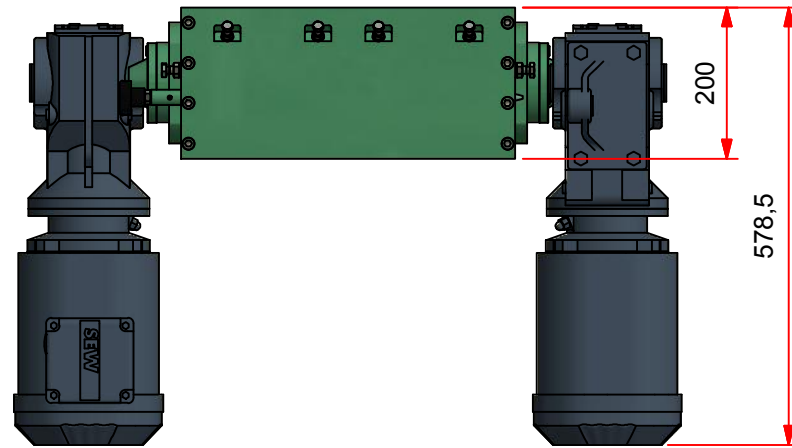
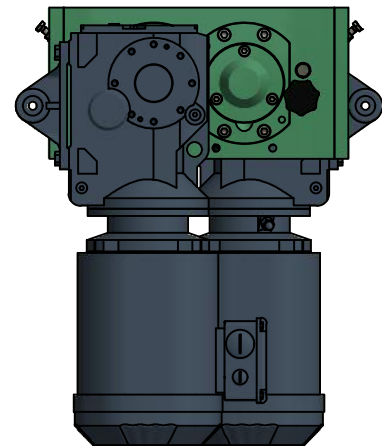
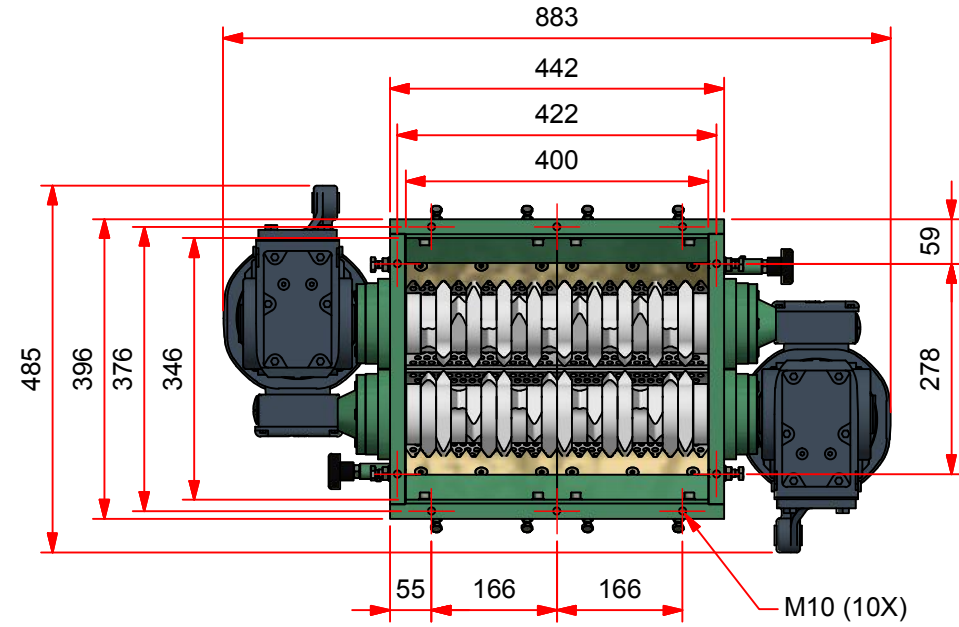

When no tolerances stated use:	
> 0.5 - 3	± 0,1
> 3 - 6	± 0,1
> 6 - 30	± 0,2
> 30 - 120	± 0,3
> 120 - 400	± 0,5
> 400 - 1000	± 0,8
> 1000 - 2000	± 1,2
> 2000 - 4000	± 2,0
> 4000 - 12000	± 4,0
> 12000 - 20000	± 6,0

Title: Shredder STS24-2.2		Customer name:	
Subtitle: Dimension drawing		Customer ref.no.:	
Mass: 201,74 kg	Drawn by: n.meersma	Date: 23-3-2016	
Stansz B.V. De Boeg 11 9206 BB Drachten Tel: 0031 (0)512 - 82 00 26 I: www.stansz.nl	Geometric tol. ISO 1101 Roughness tol. ISO 1302 General tol. ISO 2768-1 ISO 2768-2	Scale 1:10	Status DEF.
	Project number 2020.11.1080	Part number 2020.11.1080	Size A3
		Rev.	A