

Scredder STS-B14.02\_D

- Number of axles : 1 pieces
- Number of knives : 18 pieces
- Transmission : 1 x 2,2kW  
75 rpm  
400/690V 4,75/2,75A 50Hz
- Screens : holes  $\varnothing 10$ ,  $\varnothing 12$ ,  $\varnothing 14$  and  $\varnothing 16$ mm (to be determined)
- Weight : 139kg
- Color : RAL 7011 (other on request)

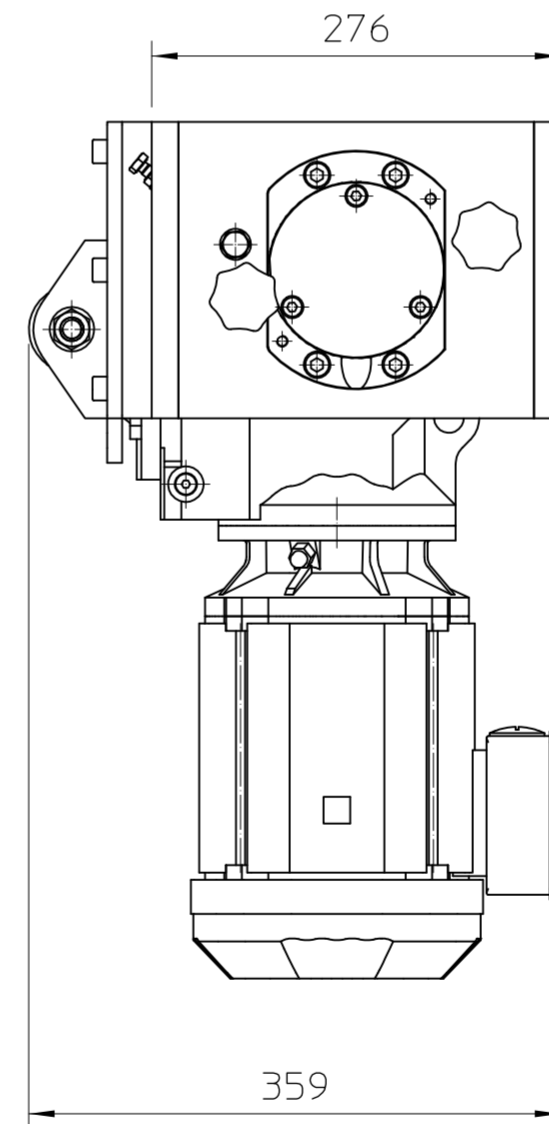
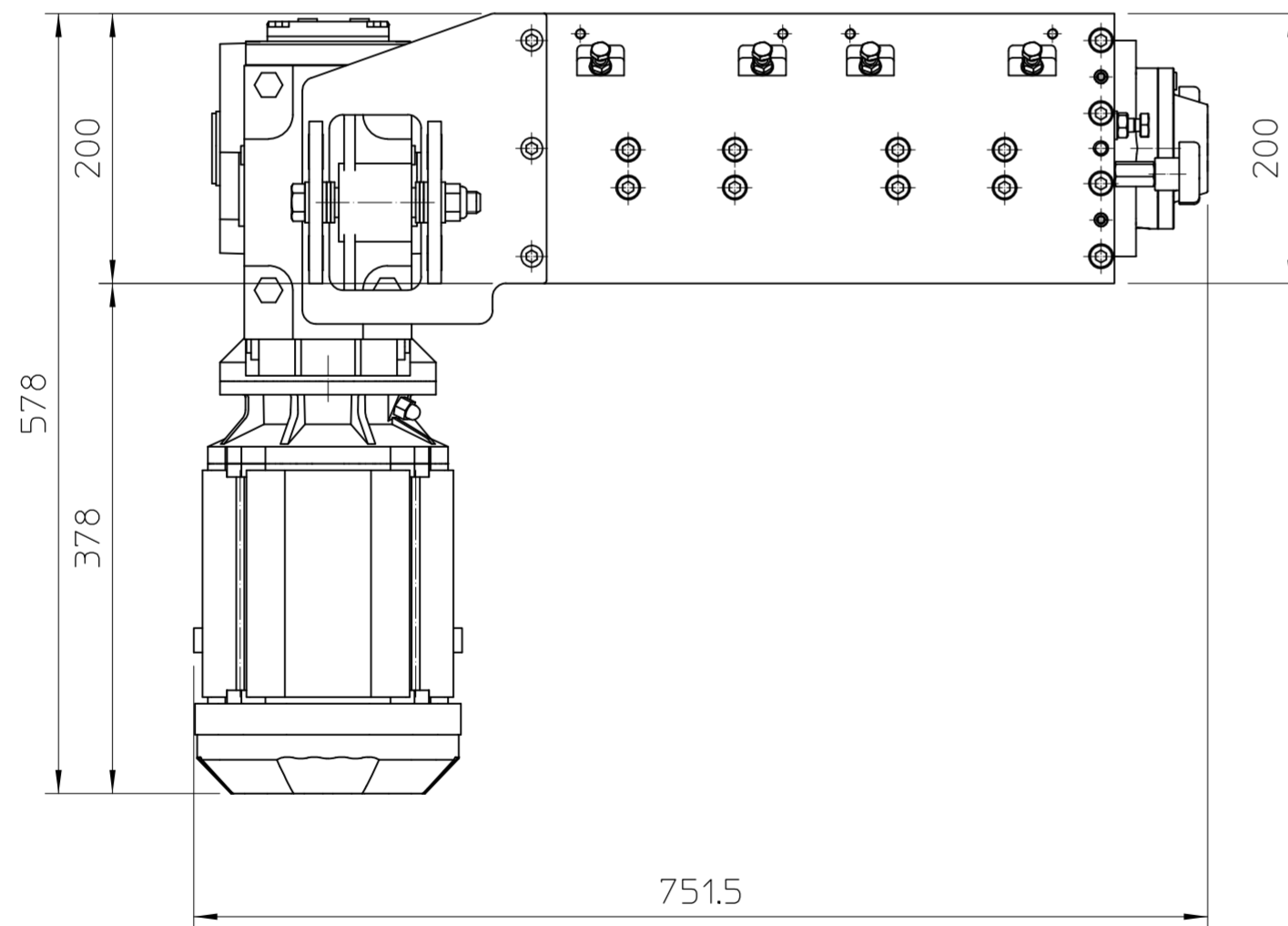

When no tol. stated use :			
0.5-	3		+0.1
>	3- 6		+0.1
>	6- 30		+0.2
>	30- 120		+0.3
>	120- 400		+0.5
>	400- 1000		+0.8
>	1000- 2000		+1.2
>	2000- 4000		+2.0
>	4000-12000		+4.0
>	12000-20000		+6.0

REV	DATE	DESIGNER	DESCRIPTION	ENG.APR.	MFG.APR.
-	-	-	-	-	-
Project:			Customer name: -		
Title:			Customer ref.no: -		
Subtitle:			Drawn by: WDV		
			Date: 13-06-2019		
			Status: DEF		
			Mass: N/A		
			Sheet		
			2 of 2		
			Scale		
			1 : 5		
			Size		
			A2		
			Project number		
			-		
			Part number		
			STS-B14.02_D		
			Rev.		
			0		

**stamach**  
presses and machinery

STAMACH  
De Boeg 11  
9206 BB Drachten  
Tel: 0031 (0)512-82 00 26  
t: www.stamach.nl

Geometric tol. ISO 1101  
Roughness tol. ISO 1302  
General tol. ISO 2768-1  
ISO 2768-2