

Shredder STS-B14.03_D

- Number of axes : 1 pieces
- Number of knives : 18 pieces
- Transmission : 1 x 3kW
75 rpm
400/690V 6,4/3,75A 50Hz
- Screens : holes $\varnothing 10$, $\varnothing 12$, $\varnothing 14$ and $\varnothing 16$ mm (to be determined)
- Weight : 146kg
- Color : Frame RAL 7035, motor RAL 5005 (other on request)

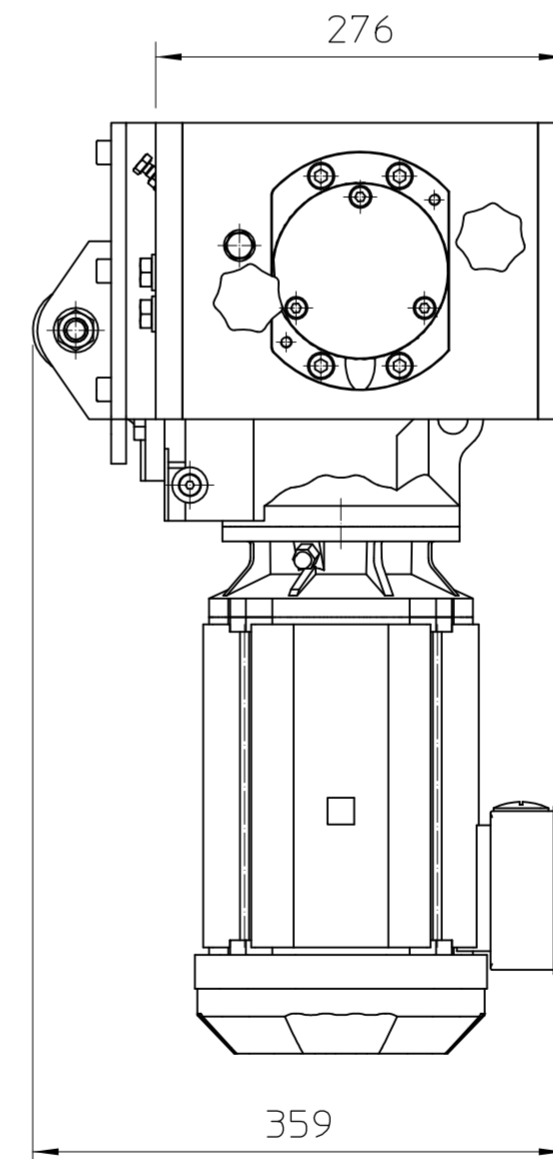

When no tol. stated use :

0.5-	3	+0.1
>	3- 6	+0.1
>	6- 30	+0.2
>	30- 120	+0.3
>	120- 400	+0.5
>	400- 1000	+0.8
>	1000- 2000	+1.2
>	2000- 4000	+2.0
>	4000-12000	+4.0
>	12000-20000	+6.0

REV	DATE	DESIGNER	DESCRIPTION	ENG.APR.	MFG.APR.
Project: -			Customer name: -		
Title: Shredder STS-B14.03_D			Customer ref.no: -		
Subtitle: Dimension Drawing			Drawn by: WDV		Date: 13-06-2019
			Status: DEF	Mass: N/A	
stamach presses and machinery STAMACH De Boeg 11 9206 BB Drachten Tel: 0031 (0)512-82 00 26 I: www.stamagr.nl			Geometric tol. ISO 1101 Roughness tol. ISO 1302 General tol. ISO 2768-1 ISO 2768-2		Sheet 2 of 2
			Scale 1 : 5		Size A2
			Project number: -	Part number: STS-B14.03_D	Rev.: 0