

Shredder STS-B16.02_S

- Number of axes : 1 pieces
- Number of knives : 28 pieces
- Transmission : 1 x 2,2kW
75 rpm
400/690V 4,75/2,75A 50Hz
- Screens : holes $\varnothing 10$, $\varnothing 12$, $\varnothing 14$ and $\varnothing 16$ mm (to be determined)
- Weight : 168kg
- Color : Frame RAL 7035, motor RAL 5005 (other on request)

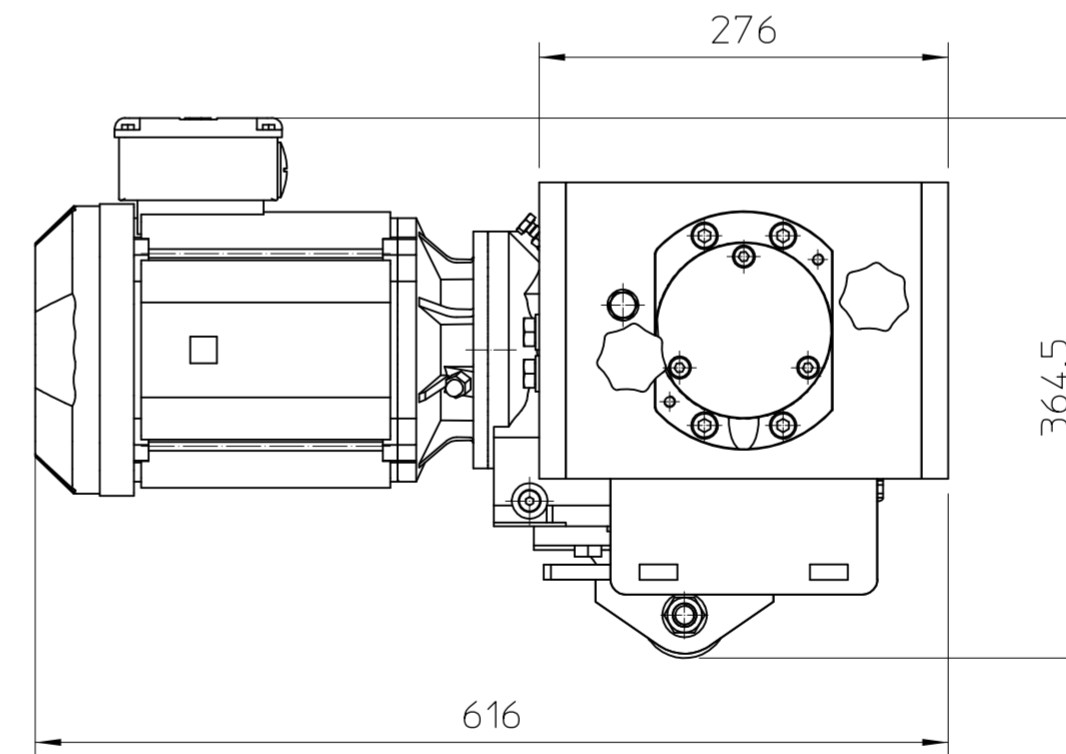

When no tol. stated use :

0.5-	3	+0.1
> 3-	6	+0.1
> 6-	30	+0.2
> 30-	120	+0.3
> 120-	400	+0.5
> 400-	1000	+0.8
> 1000-	2000	+1.2
> 2000-	4000	+2.0
> 4000-	12000	+4.0
> 12000-	20000	+6.0

REV	DATE	DESIGNER	DESCRIPTION	ENG.APR.	MFG.APR.
Project: -			Customer name: -		
Title: Shredder STS-B16.02_S			Customer ref.no: -		
Subtitle: Dimension Drawing			Drawn by: WDV	Date: 13-06-2019	
			Status: DEF	Mass: N/A	
			Geometric tol. ISO 1101 Roughness tol. ISO 1302 General tol. ISO 2768-1 ISO 2768-2		Sheet 2 of 2 Scale 1 : 5 Size A2
			Project number -	Part number STS-B16.02_S	Rev. 0