

Shredder STS-B16.02_U

- Number of axles : 1 pieces
- Number of knives : 28 pieces
- Transmission : 1 x 2,2kW
75 rpm
400/690V 4,75/2,75A 50Hz
- Screens : holes $\varnothing 10$, $\varnothing 12$, $\varnothing 14$ and $\varnothing 16$ mm (to be determined)
- Weight : 168kg
- Color : Frame RAL 7035, motor RAL 5005 (other on request)

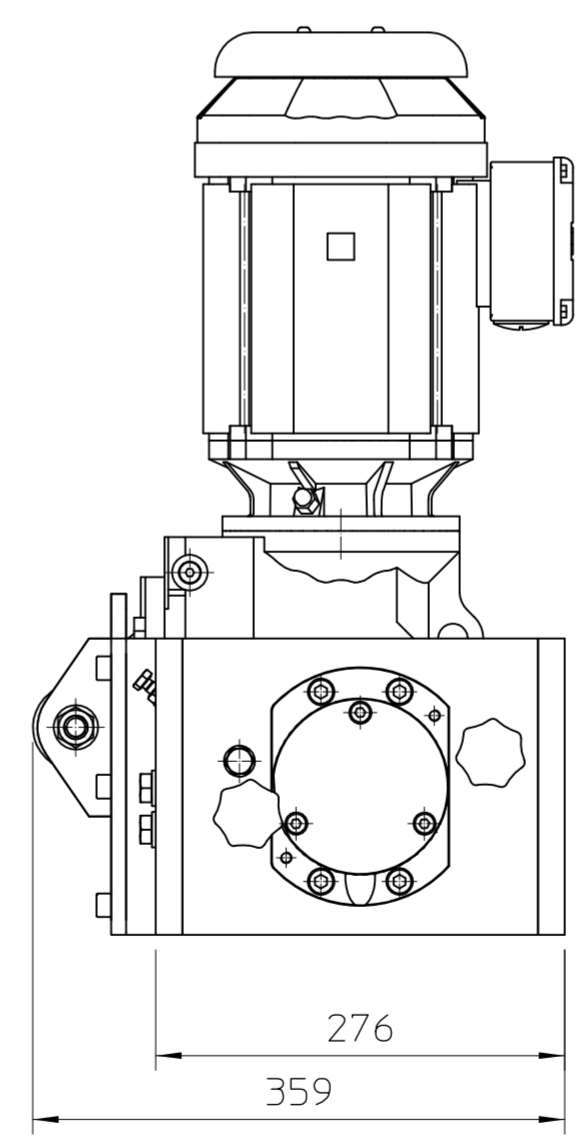
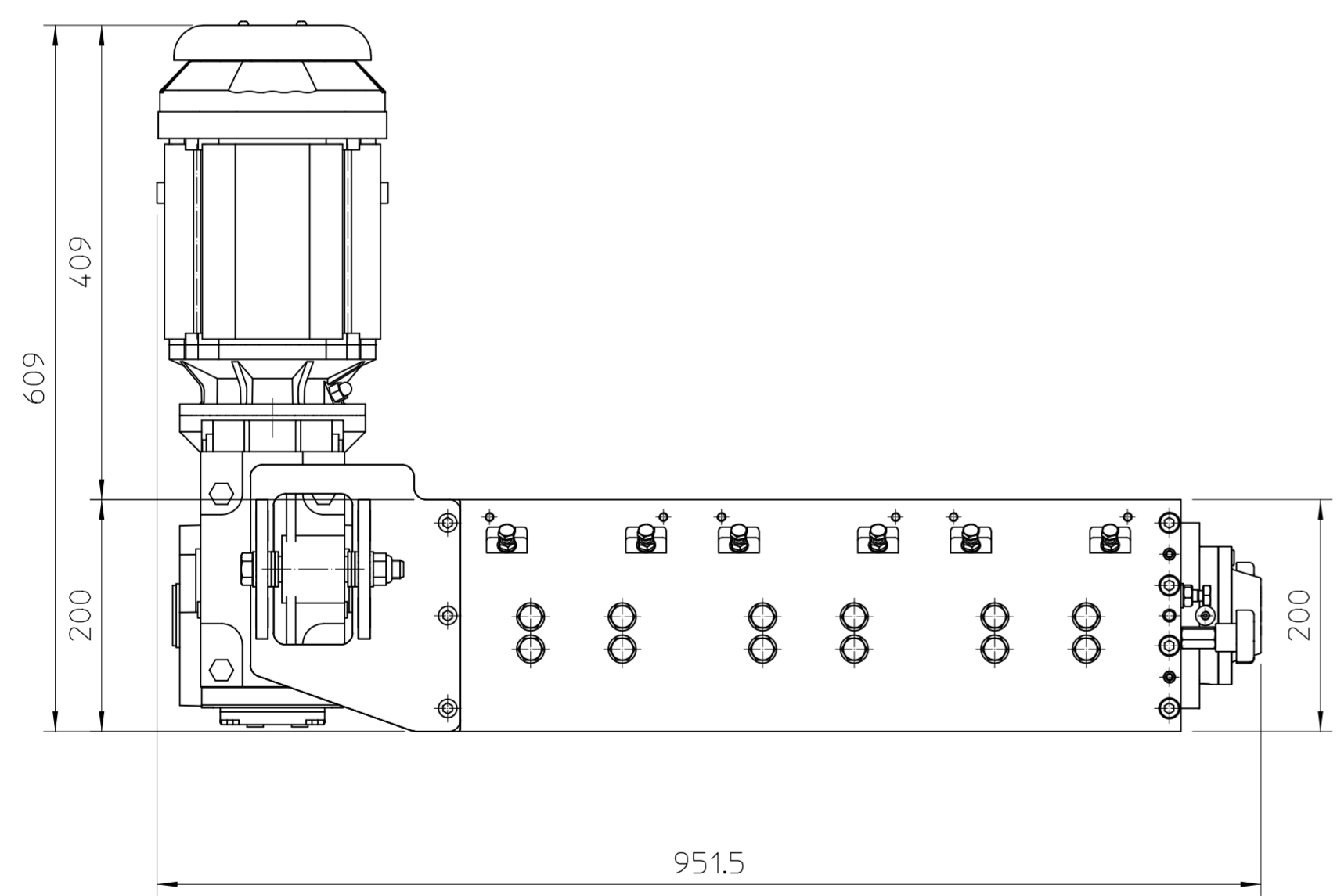

When no tol. stated use :

0.5- 3	+0.1
> 3- 6	+0.1
> 6- 30	+0.2
> 30- 120	+0.3
> 120- 400	+0.5
> 400- 1000	+0.8
> 1000- 2000	+1.2
> 2000- 4000	+2.0
> 4000- 12000	+4.0
> 12000- 20000	+6.0

REV	DATE	DESIGNER	DESCRIPTION	ENG.APR.	MFG.APR.
-	-	-	-	-	-
Project: -			Customer name: -		
Title: Shredder STS-B16.02_U			Customer ref.no: -		
Subtitle: Dimension Drawing			Date: 13-06-2019		
Status: DEF			Mass: N/A		
 stamach presses and machinery		STAMACH De Boeg 11 9206 BB Drachten Tel: 0031 (0)512-82 00 26 I: www.stamag.nl		Geometric tol. ISO 1101 Roughness tol. ISO 1302 General tol. ISO 2768-1 ISO 2768-2	
Project number: -		Sheet: 2 of 2		Scale: 1 : 5	
Part number: STS-B16.02_U		Size: A2		Rev.: 0	