

Shredder STS-B16.03_D

- Number of axles : 1 pieces
- Number of knives : 28 pieces
- Transmission : 1 x 3kW
75 rpm
400/690V 6,4/3,75A 50Hz
- Screens : holes $\varnothing 10$, $\varnothing 12$, $\varnothing 14$ and $\varnothing 16$ mm (to be determined)
- Weight : 175kg
- Color : Frame RAL 7035, motor RAL 5005 (other on request)

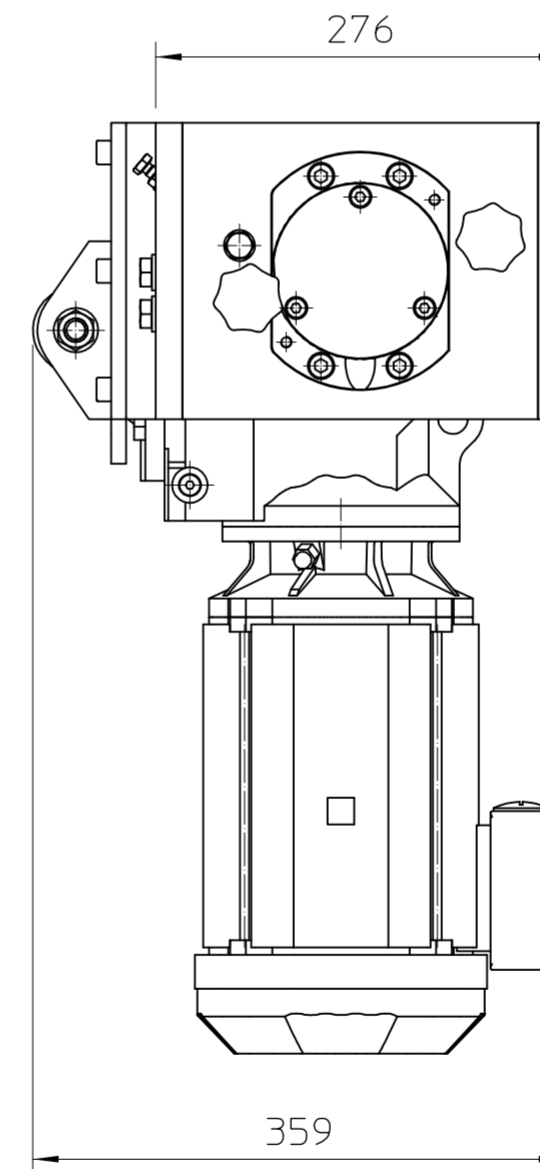
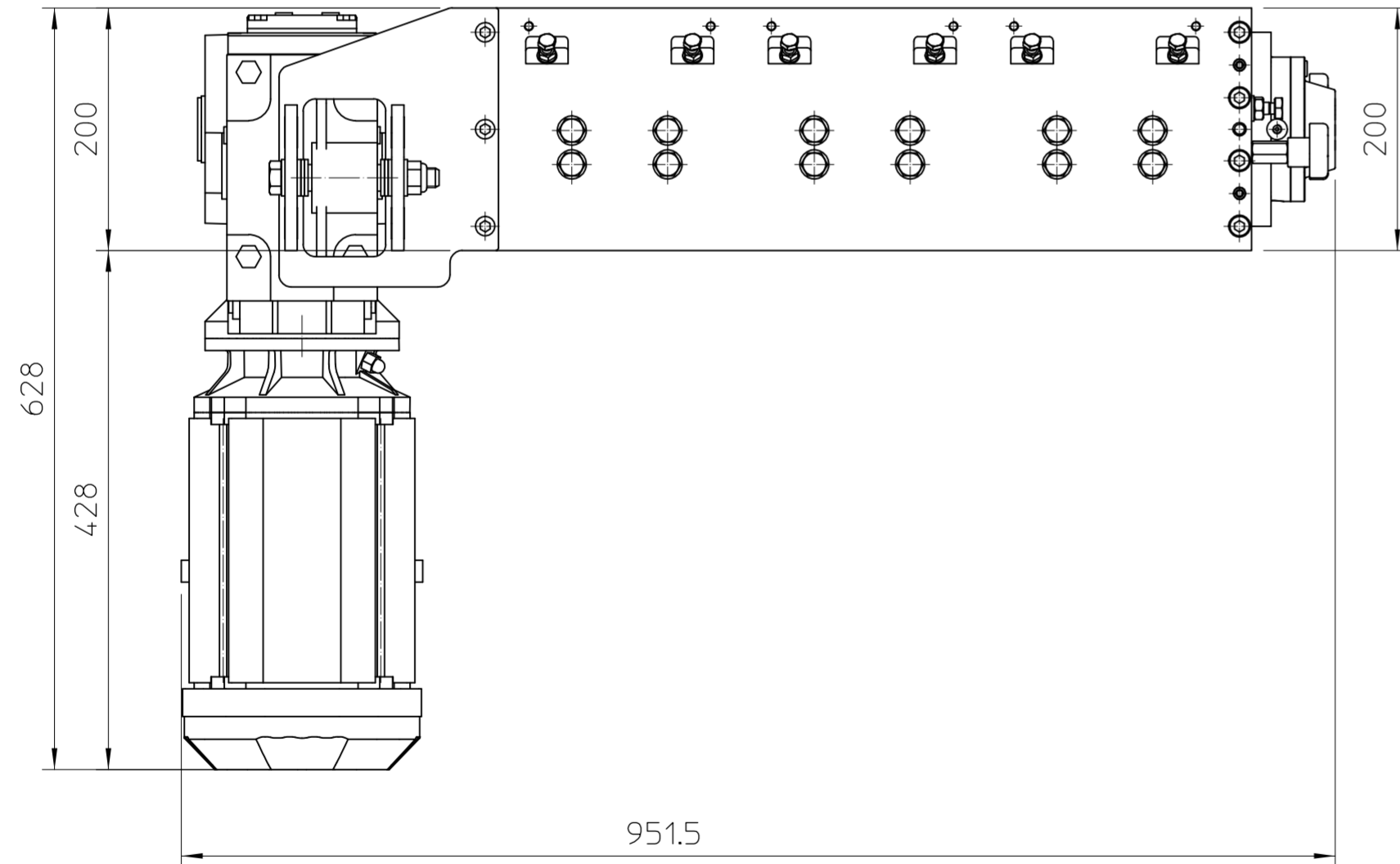

When no tol. stated use :

0.5-	3-	6	+0.1
>	6-	30	+0.1
>	30-	120	+0.2
>	120-	400	+0.3
>	400-	1000	+0.5
>	1000-	2000	+0.8
>	2000-	4000	+1.2
>	4000-	12000	+2.0
>	12000-	20000	+4.0
>	>12000-	>20000	+6.0

REV	DATE	DESIGNER	DESCRIPTION	ENG.APR.	MFG.APR.
Project: -					
Title: Shredder STS-B16.03_D					
Subtitle: Dimension Drawing					
Customer name: -				Customer ref.no: -	
Drawn by: WDV				Date: 13-06-2019	
Status: DEF				Mass: N/A	
		STAMACH De Boeg 11 9206 BB Drachten Tel: 0031 (0)512-82 00 26 I: www.stamagr.nl		Geometric tol. ISO 1101 Roughness tol. ISO 1302 General tol. ISO 2768-1 ISO 2768-2	
Sheet		Scale		Size	
2 of 2		1 : 5		A2	
Project number		Part number		Rev.	
-		STS-B16.03_D		0	