

Shredder STS-B24.02_DS

- Number of axles : 2 pieces
- Number of knives : 36 pieces
- Transmission : 2 x 2,2kW
75 rpm
400/690V 4,75/2,75A 50Hz
- Screens : holes $\varnothing 10$, $\varnothing 12$, $\varnothing 14$ and $\varnothing 16$ mm (to be determined)
- Weight : 236kg
- Color : Frame RAL 7035, motor RAL 5005 (other on request)

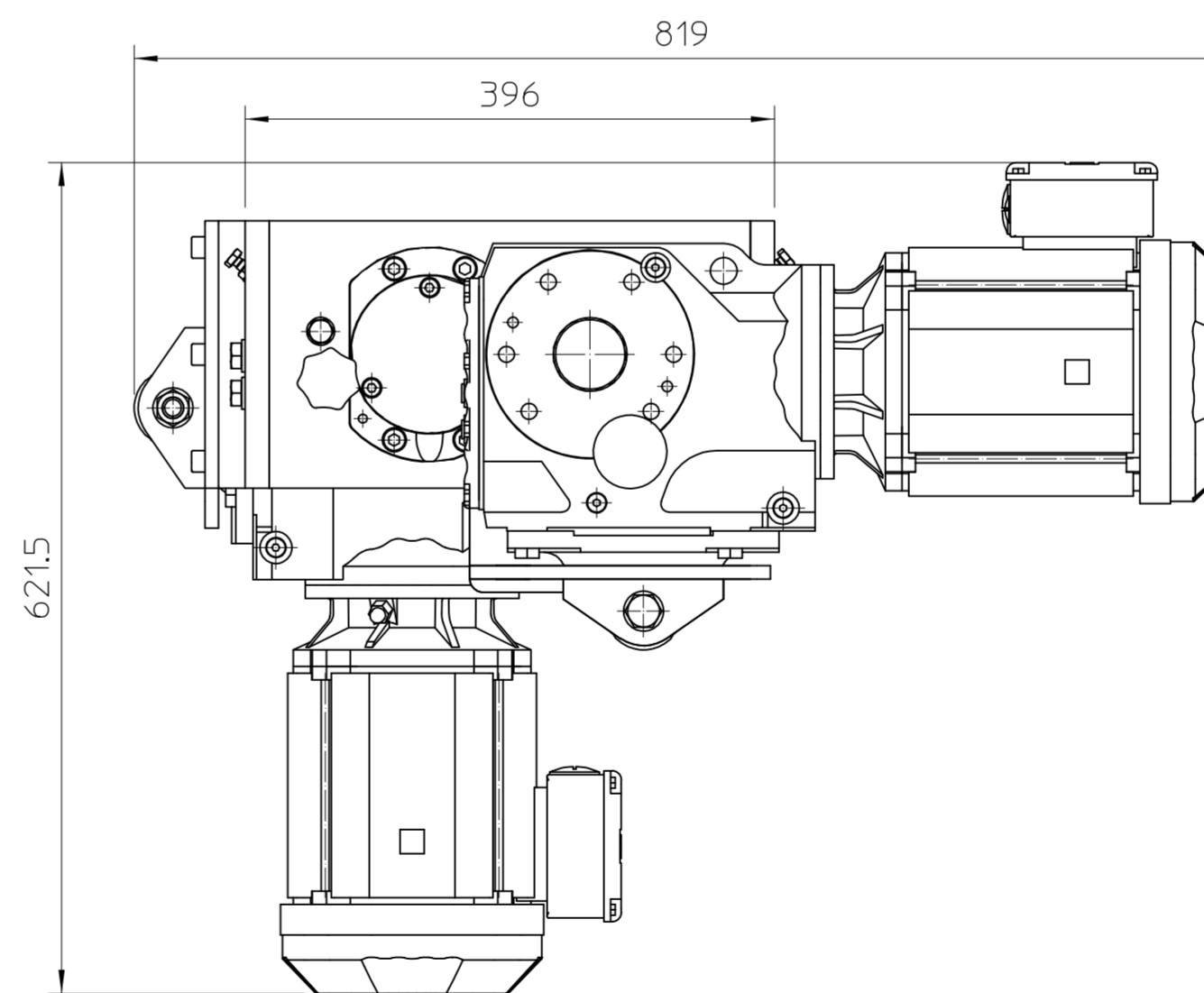
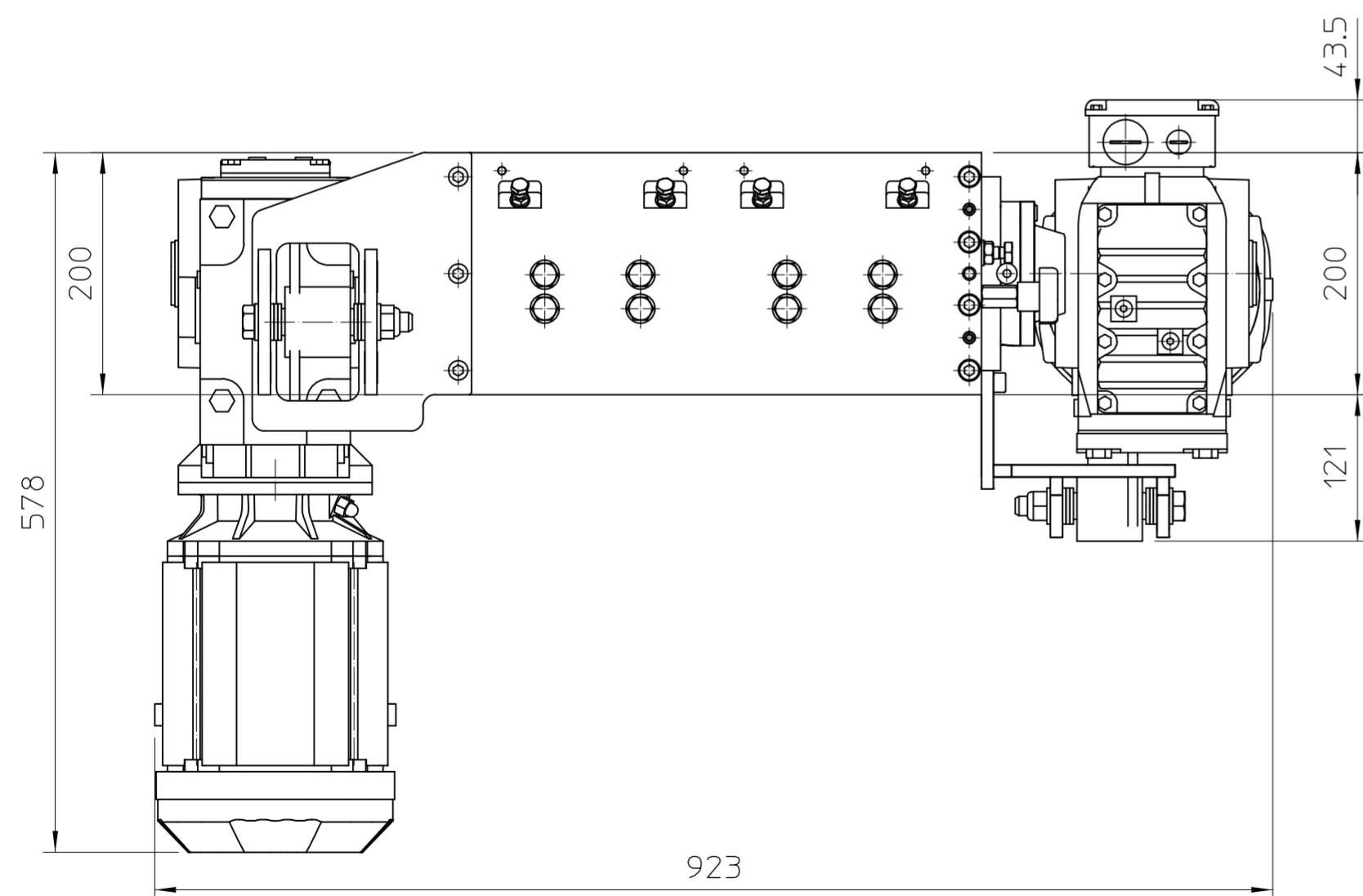

When no tol. stated use :

0.5-	3	+0.1
>	3- 6	+0.1
>	6- 30	+0.2
>	30- 120	+0.3
>	120- 400	+0.5
>	400- 1000	+0.8
>	1000- 2000	+1.2
>	2000- 4000	+2.0
>	4000-12000	+4.0
>	12000-20000	+6.0

REV	DATE	DESIGNER	DESCRIPTION	ENG.APR.	MFG.APR.
Project: -					
Title: Shredder STS-B24.02_DS Dimension Drawing					
Customer name: -					
Customer ref.no: -					
Drawn by: WDV				Date: 12-06-2019	
Status: DEF				Mass: N/A	
Geometric tol. ISO 1101		STAMACH De Boeg 11 9206 BB Drachten Tel: 0031 (0)512-82 00 26 t: www.stamag.nl		Sheet 2 of 2	
Roughness tol. ISO 1302				Scale 1 : 5	
General tol. ISO 2768-1				Size A2	
ISO 2768-2		Project number -		Part number STS-B24.02_DS	
				Rev. 0	