

Shredder STS-B24.02\_DU

- Number of axles : 2 pieces
- Number of knives : 36 pieces
- Transmission : 2 x 2,2kW  
75 rpm  
400/690V 4,75/2,75A 50Hz
- Screens : holes  $\varnothing 10$ ,  $\varnothing 12$ ,  $\varnothing 14$  and  $\varnothing 16$ mm (to be determined)
- Weight : 236kg
- Color : Frame RAL 7035, motor RAL 5005 (other on request)

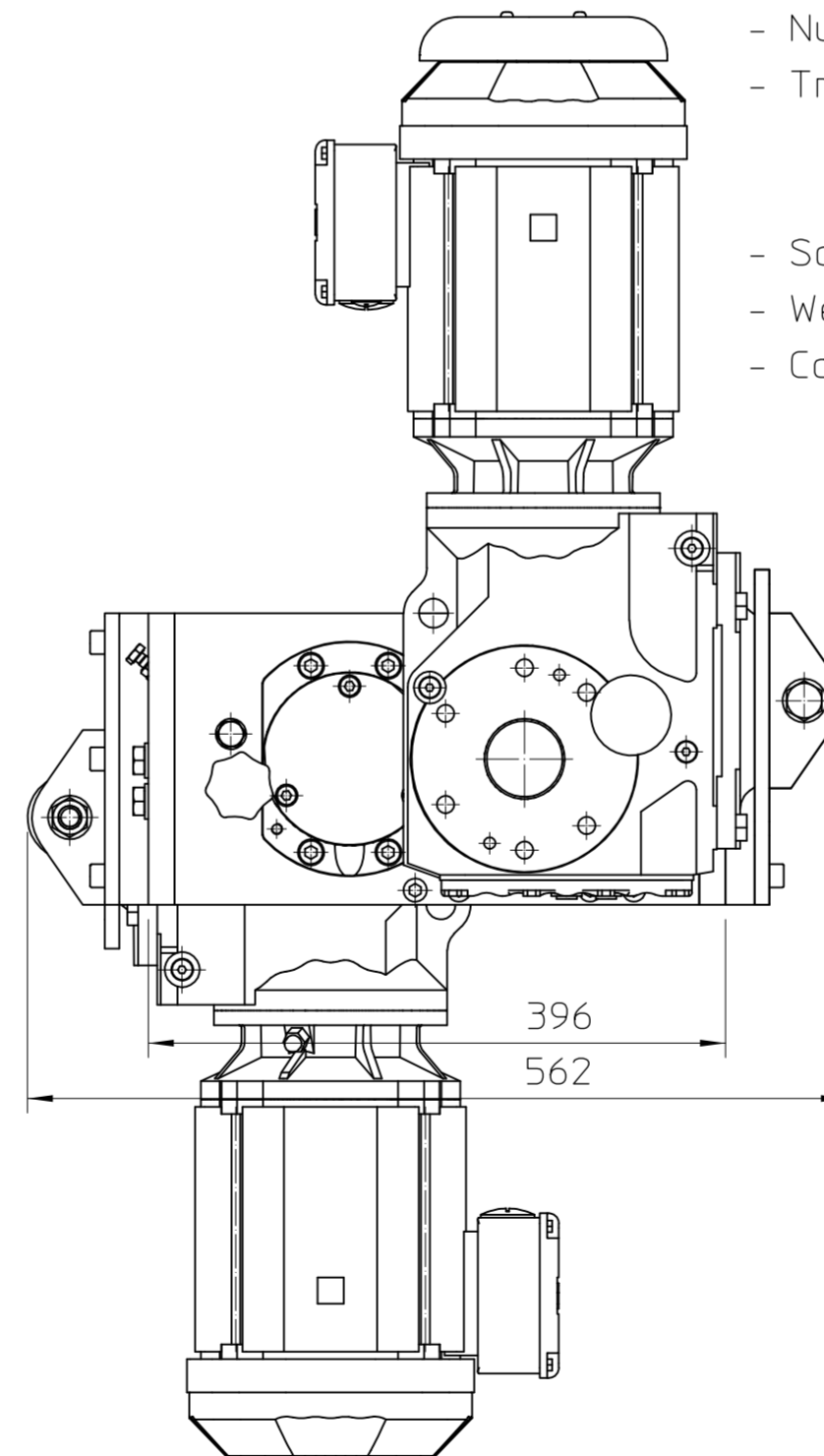
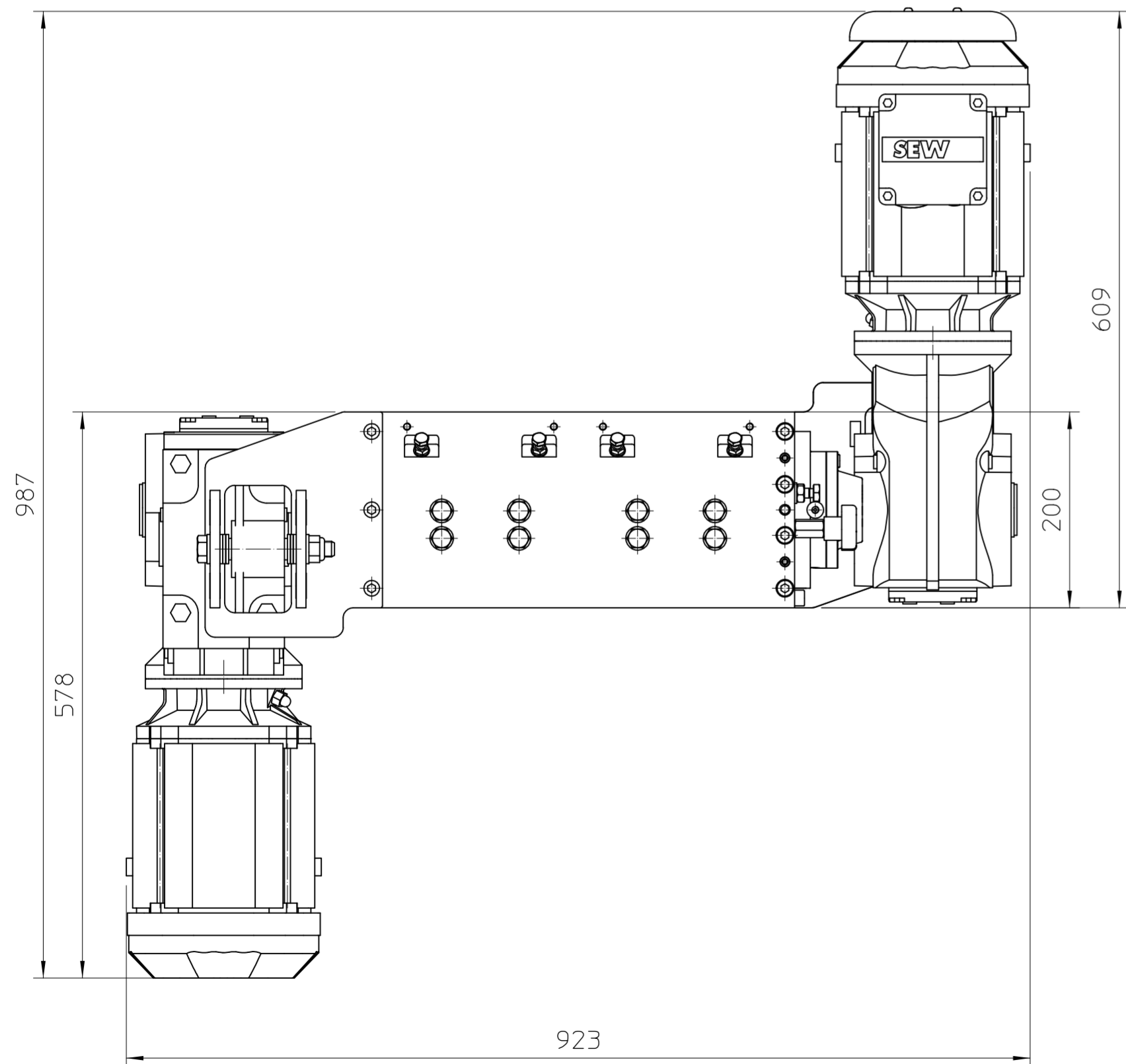

When no tol. stated use :

0.5-	3	+0.1
>	6	+0.1
>	30	+0.2
>	120	+0.3
>	400	+0.5
>	1000	+0.8
>	2000	+1.2
>	4000	+2.0
>	12000	+4.0
>	20000	+6.0

REV	DATE	DESIGNER	DESCRIPTION	ENG.APR.	MFG.APR.
Project: -			Customer name: -		
Title: Shredder STS-B24.02_DU			Customer ref.no: -		
Subtitle: Dimension Drawing			Drawn by: WDV	Date: 12-06-2019	
			Status: DEF	Mass: N/A	
			Geometric tol. ISO 1101 Roughness tol. ISO 1302 General tol. ISO 2768-1 ISO 2768-2		Sheet 2 of 2 Scale 1:5 Size A2
			Project number -	Part number STS-B24.02_DU	Rev. 0