

Shredder STS-B24.02_D

- Number of axles : 2 pieces
- Number of knives : 36 pieces
- Transmission : 2 x 2,2kW
75 rpm
400/690V 4,75/2,75A 50Hz
- Screens : holes $\varnothing 10$, $\varnothing 12$, $\varnothing 14$ and $\varnothing 16$ mm (to be determined)
- Weight : 236kg
- Color : Frame RAL 7035, motor RAL 5005 (other on request)

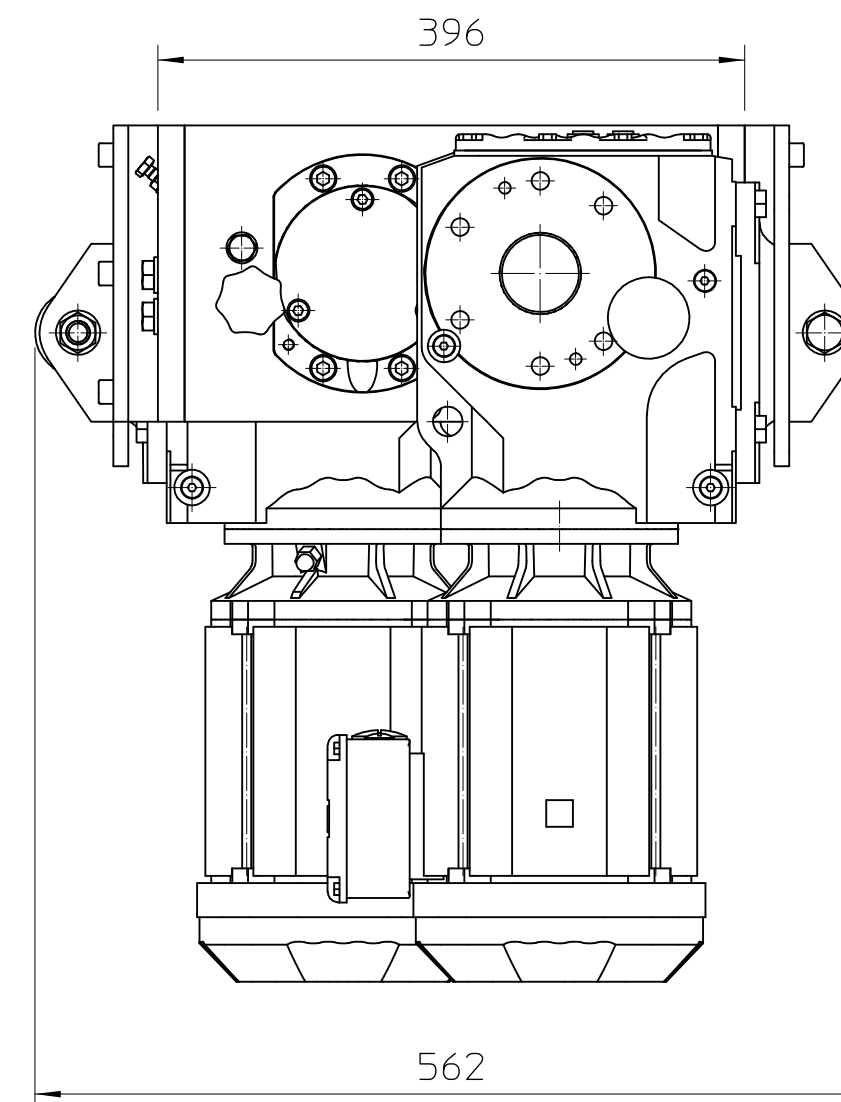
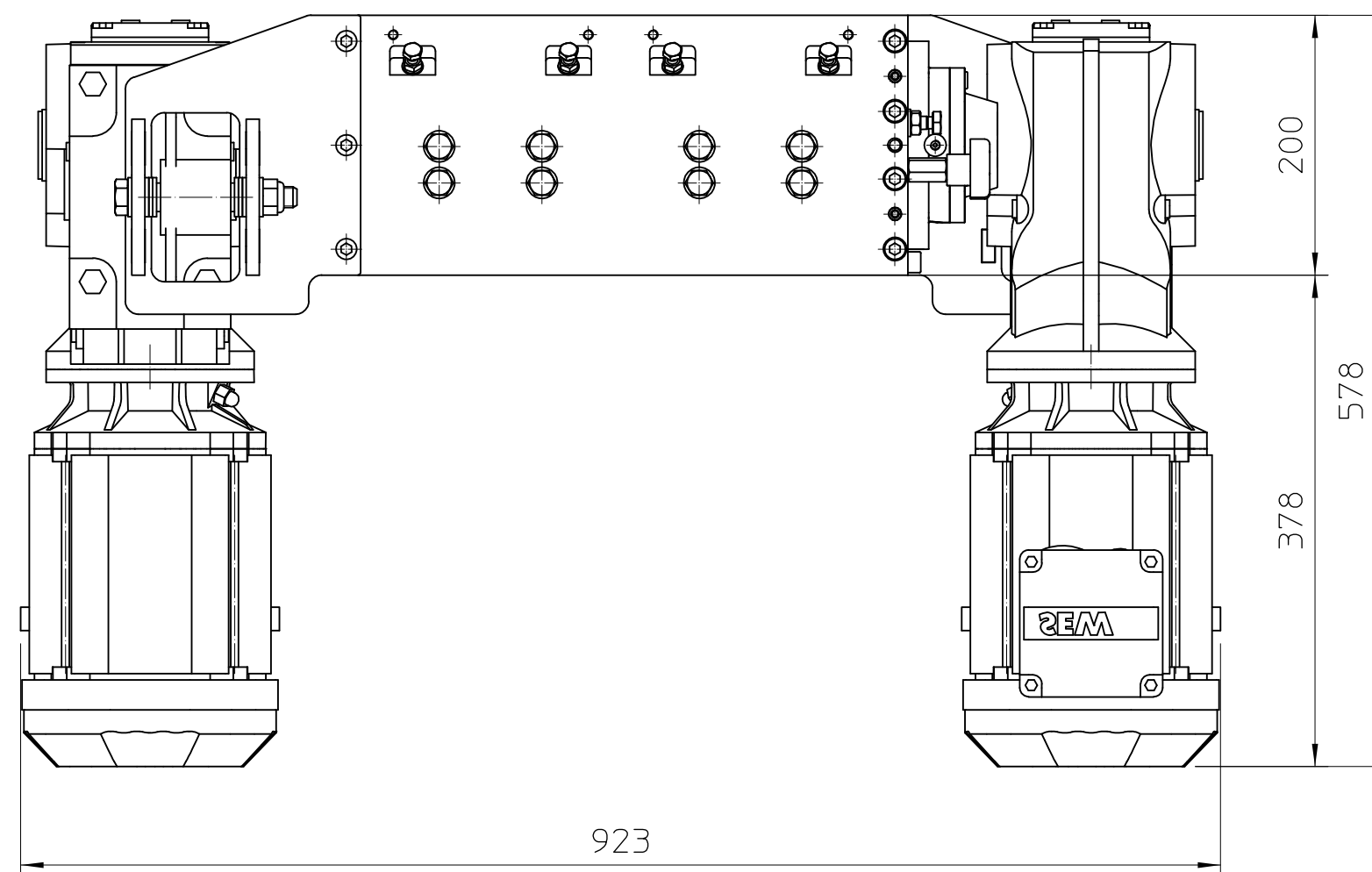

When no tol. stated use :			
0.5-	3-	6	+0.1
>	6-	30	+0.1
>	30-	120	+0.2
>	120-	400	+0.3
>	400-	1000	+0.5
>	1000-	2000	+1.2
>	2000-	4000	+2.0
>	4000-	12000	+4.0
>	12000-	20000	+6.0

REV	DATE	DESIGNER	DESCRIPTION	ENG.APR.	MFG.APR.
-	-	-	-	-	-
Project:			Customer name: -		
Title:			Customer ref.no: -		
Subtitle:			Drawn by: WDV		
			Date: 12-06-2019		
			Status: DEF		
			Mass: N/A		
			Sheet		
			2 of 2		
			Scale		
			1 : 5		
			Size		
			A2		
			Project number		
			-		
			Part number		
			STS-B24.02_D		
			Rev.		
			0		

stamach
presses and machinery

STAMACH
De Boeg 11
9206 BB Drachten
Tel: 0031 (0)512-82 00 26
I: www.stamach.nl

Geometric tol. ISO 1101
Roughness tol. ISO 1302
General tol. ISO 2768-1
ISO 2768-2