

Shredder STS-B24.03_US

- Number of axles : 2 pieces
- Number of knives : 36 pieces
- Transmission : 2 x 3kW
75 rpm
400/690V 6,4/3,75A 50Hz
- Screens : holes $\varnothing 10$, $\varnothing 12$, $\varnothing 14$ and $\varnothing 16$ mm (to be determined)
- Weight : 250kg
- Color : Frame RAL 7035, motor RAL 5005 (other on request)

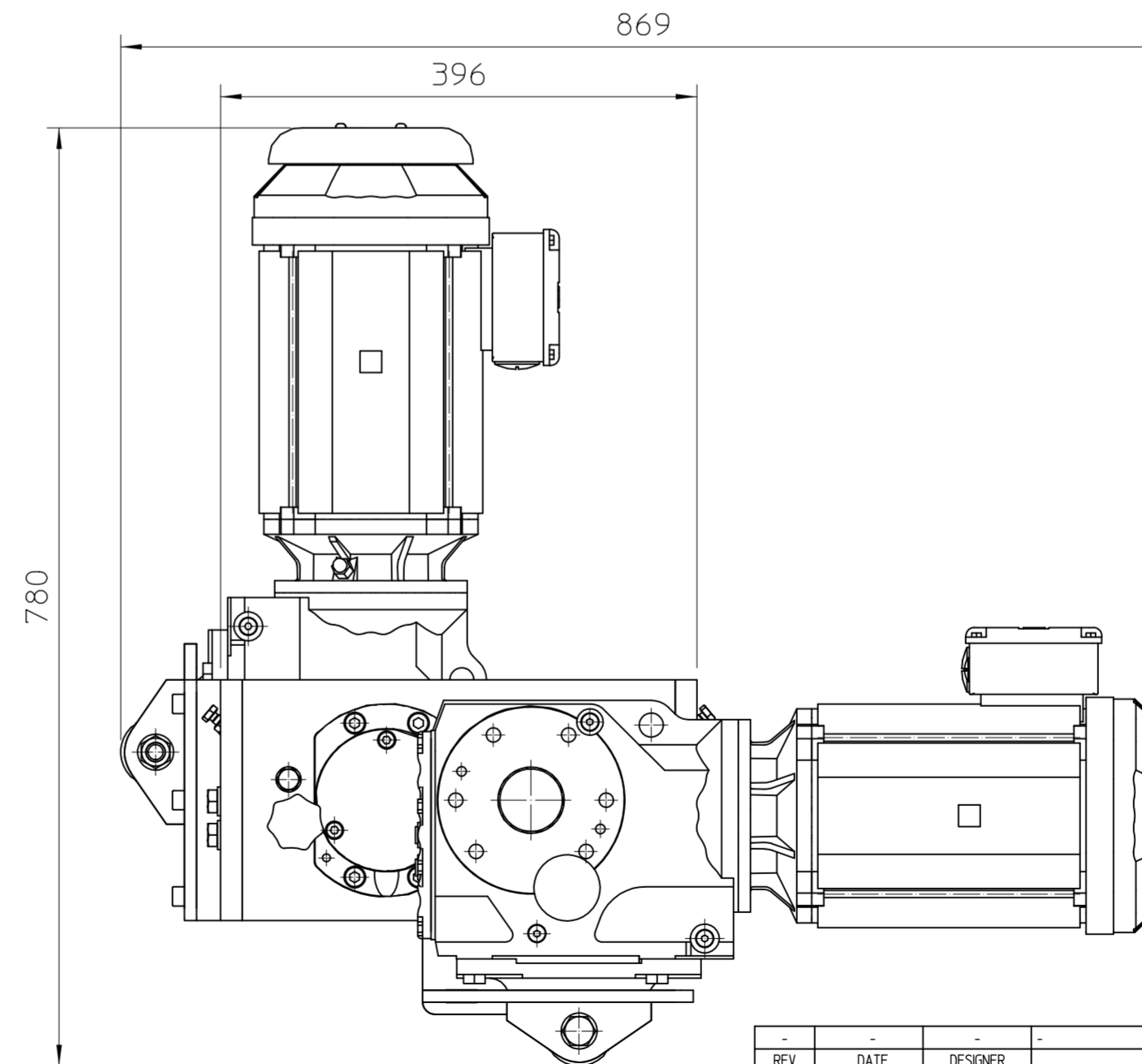

When no tol. stated use :		
0.5-	3-	+0.1
>	6-	+0.1
>	30-	+0.2
>	120-	+0.3
>	400-	+0.5
>	1000-	+0.8
>	2000-	+1.2
>	4000-	+2.0
>	12000-	+4.0
>	20000-	+6.0

REV	DATE	DESIGNER	DESCRIPTION	ENG.APR.	MFG.APR.
Project: -			Customer name: -		
Title: Shredder STS-B24.03_US			Customer ref.no: -		
Subtitle: Dimension Drawing			Drawn by: WDV	Date: 12-06-2019	
			Status: DEF	Mass: N/A	
stamach <small>presses and machinery</small>			<small>STAMACH</small> <small>De Boeg 11</small> <small>9206 BB Drachten</small> <small>Tel: 0031 (0)512-82 00 26</small> <small>l: www.stamagr.nl</small>	<small>Geometric tol. ISO 1101</small> <small>Roughness tol. ISO 1302</small> <small>General tol. ISO 2768-1</small> <small>ISO 2768-2</small>	
			<small>Sheet</small> 2 of 2	<small>Scale</small> 1 : 5	<small>Size</small> A2
			<small>Project number</small> -	<small>Part number</small> STS-B24.03_US	<small>Rev.</small> 0