

Shredder STS-B26.02_D

- Number of axles : 2 pieces
- Number of knives : 56 pieces
- Transmission : 2 x 2,2kW
75 rpm
400/690V 4,75/2,75A 50Hz
- Screens : holes $\varnothing 10$, $\varnothing 12$, $\varnothing 14$ and $\varnothing 16$ mm (to be determined)
- Weight : 275kg
- Color : Frame RAL 7035, motor RAL 5005 (other on request)

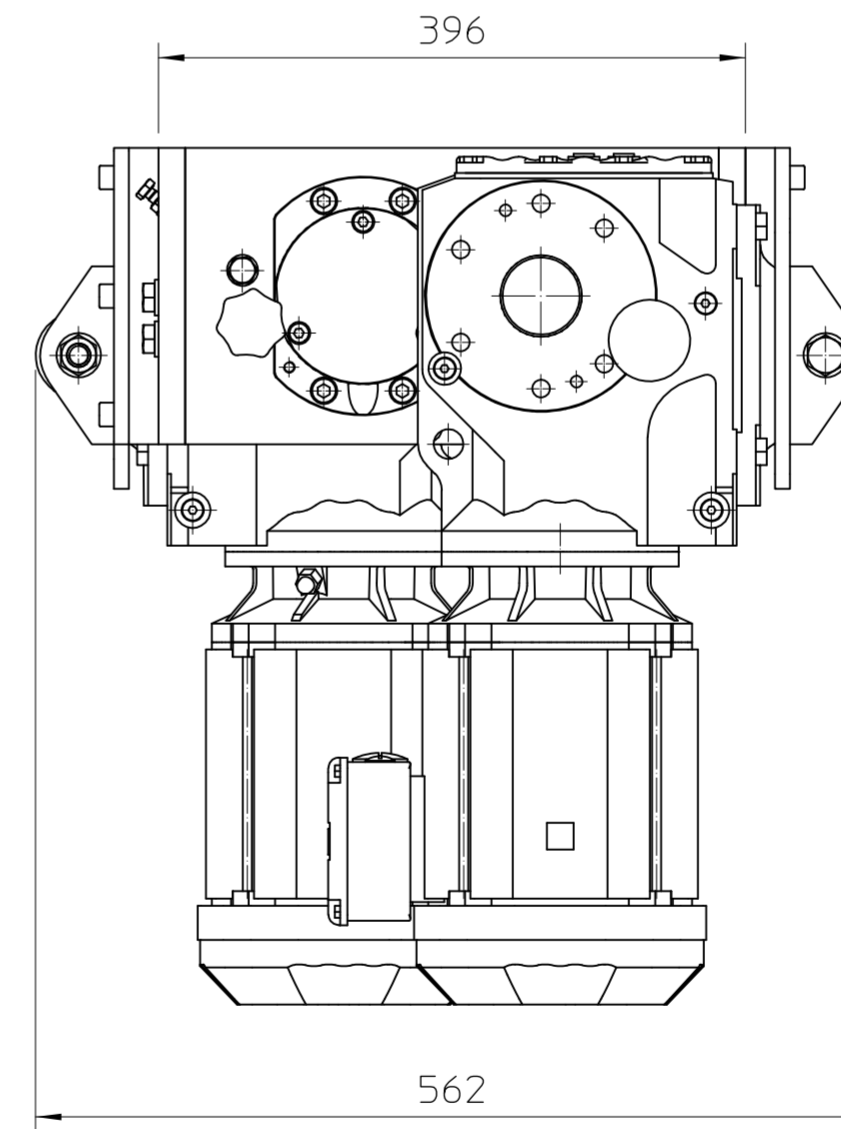

When no tol. stated use :		
0.5-	3-	+0.1
>	6-	+0.1
>	30-	+0.2
>	120-	+0.3
>	400-	+0.5
>	1000-	+0.8
>	2000-	+1.2
>	4000-	+2.0
>	12000-	+4.0
>	20000-	+6.0

REV	DATE	DESIGNER	DESCRIPTION	ENG.APR.	MFG.APR.
Project: -			Customer name: -		
Title: Shredder STS-B26.02_D			Customer ref.no: -		
Subtitle: Dimension Drawing			Drawn by: WDV	Date: 12-06-2019	
			Status: DEF	Mass: N/A	
			Geometric tol. ISO 1101 Roughness tol. ISO 1302 General tol. ISO 2768-1 ISO 2768-2		Sheet 2 of 2 Scale 1:5 Size A2
			Project number -	Part number STS-B26.02_D	Rev. 0