

Shredder STS-B26.02-S

- Number of axles : 2 pieces
- Number of knives : 56 pieces
- Transmission : 2 x 2,2kW
75 rpm
400/690V 4,75/2,75A 50Hz
- Screens : holes $\varnothing 10$, $\varnothing 12$, $\varnothing 14$ and $\varnothing 16$ mm (to be determined)
- Weight : 275kg
- Color : Frame RAL 7035, motor RAL 5005 (other on request)

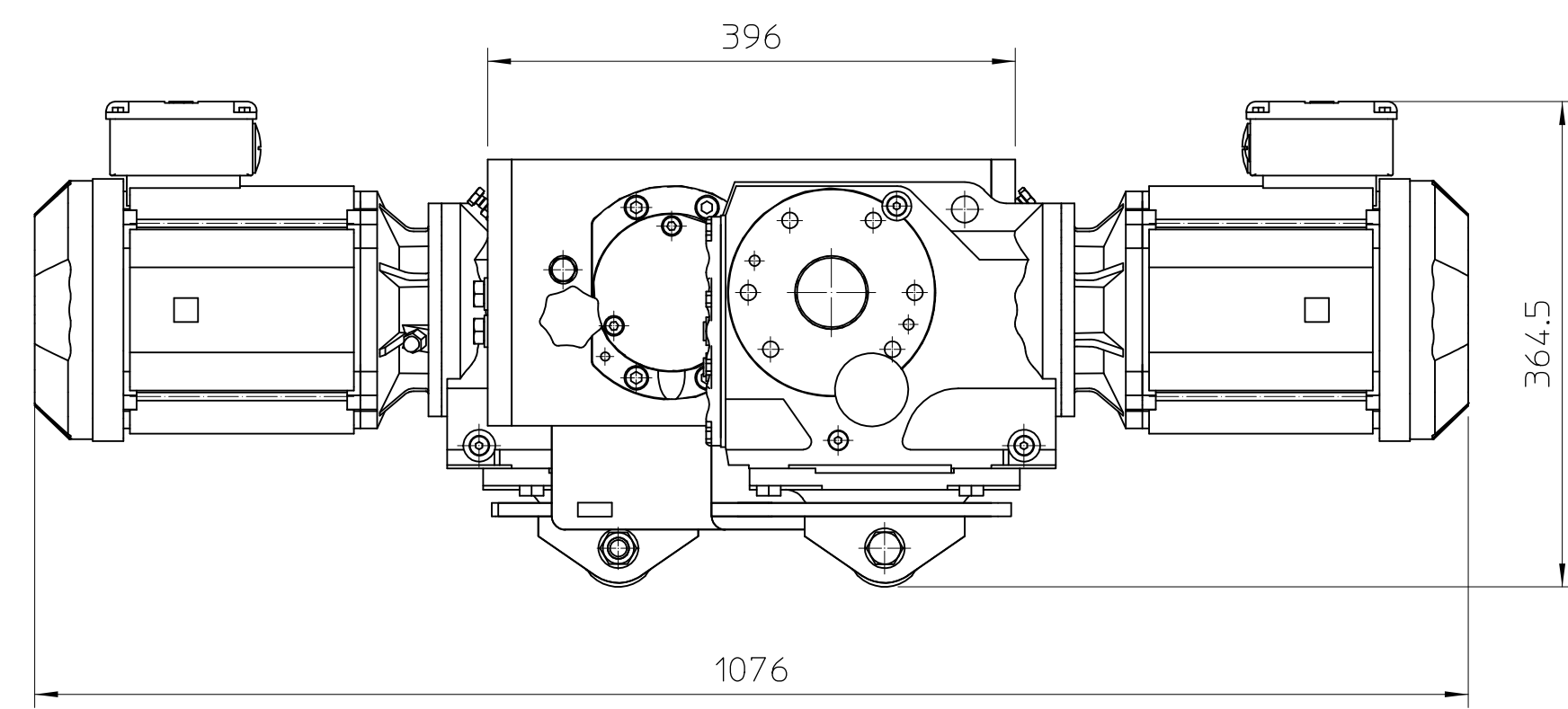
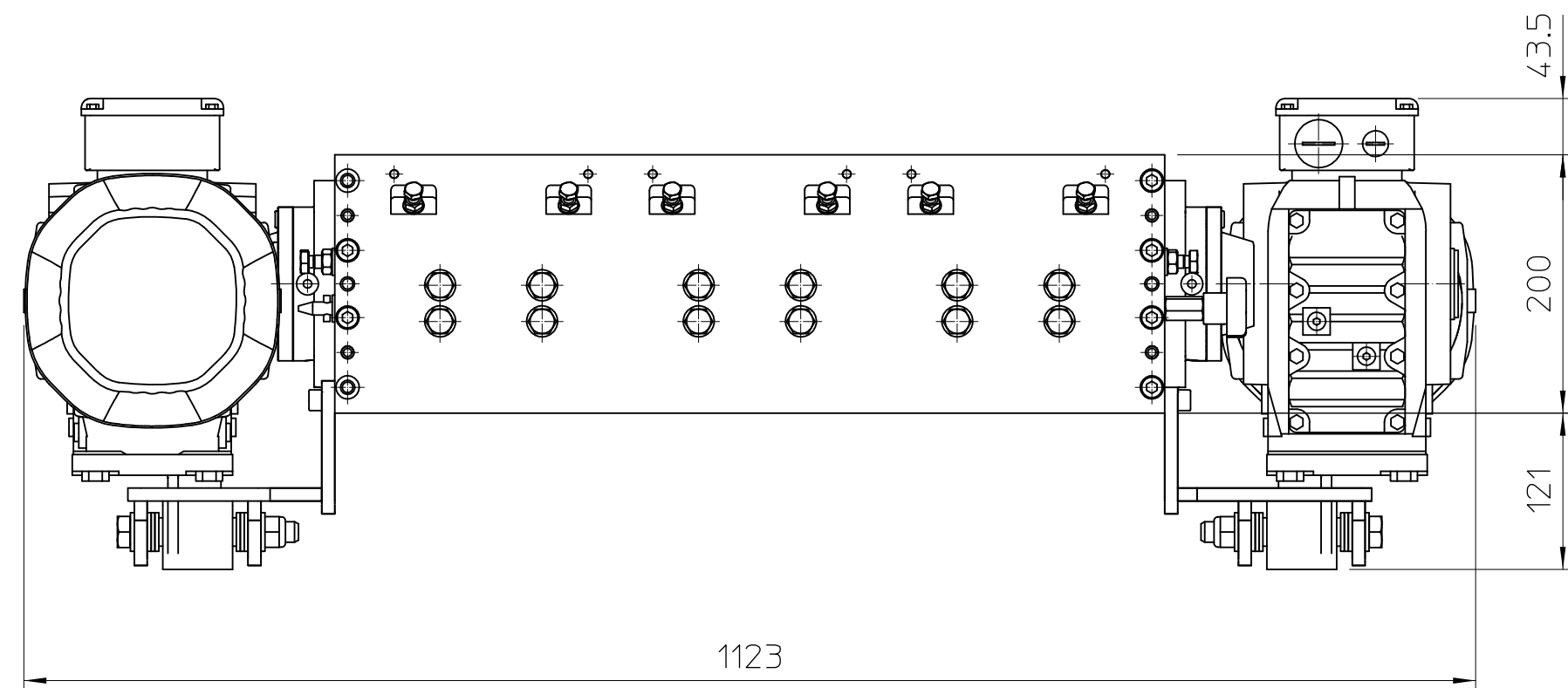

When no tol. stated use :

0.5-	3-	6	+0.1
>	30-	120	+0.1
>	6-	30	+0.2
>	30-	120	+0.3
>	120-	400	+0.5
>	400-	1000	+0.8
>	1000-	2000	+1.2
>	2000-	4000	+2.0
>	4000-	12000	+4.0
>	12000-	20000	+6.0

REV	DATE	DESIGNER	DESCRIPTION	ENG.APR.	MFG.APR.
Project: -			Customer name: -		
Title: Shredder STS-B26.02_S Dimension Drawing			Customer ref.no: -		
Subtitle: -			Drawn by: WDV		Date: 12-06-2019
			Status: DEF		Mass: N/A
			Sheet 2 of 2		Scale 1:5
			Project number -		Part number STS-B26.02_S
					Size A2
					Rev. 0