

Shredder STS-B26.03-US

- Number of axles : 2 pieces
- Number of knives : 56 pieces
- Transmission : 2 x 3kW
75 rpm
400/690V 6,4/3,75A 50Hz
- Screens : holes $\varnothing 10$, $\varnothing 12$, $\varnothing 14$ and $\varnothing 16$ mm (to be determined)
- Weight : 289kg
- Color : Frame RAL 7035, motor RAL 5005 (other on request)

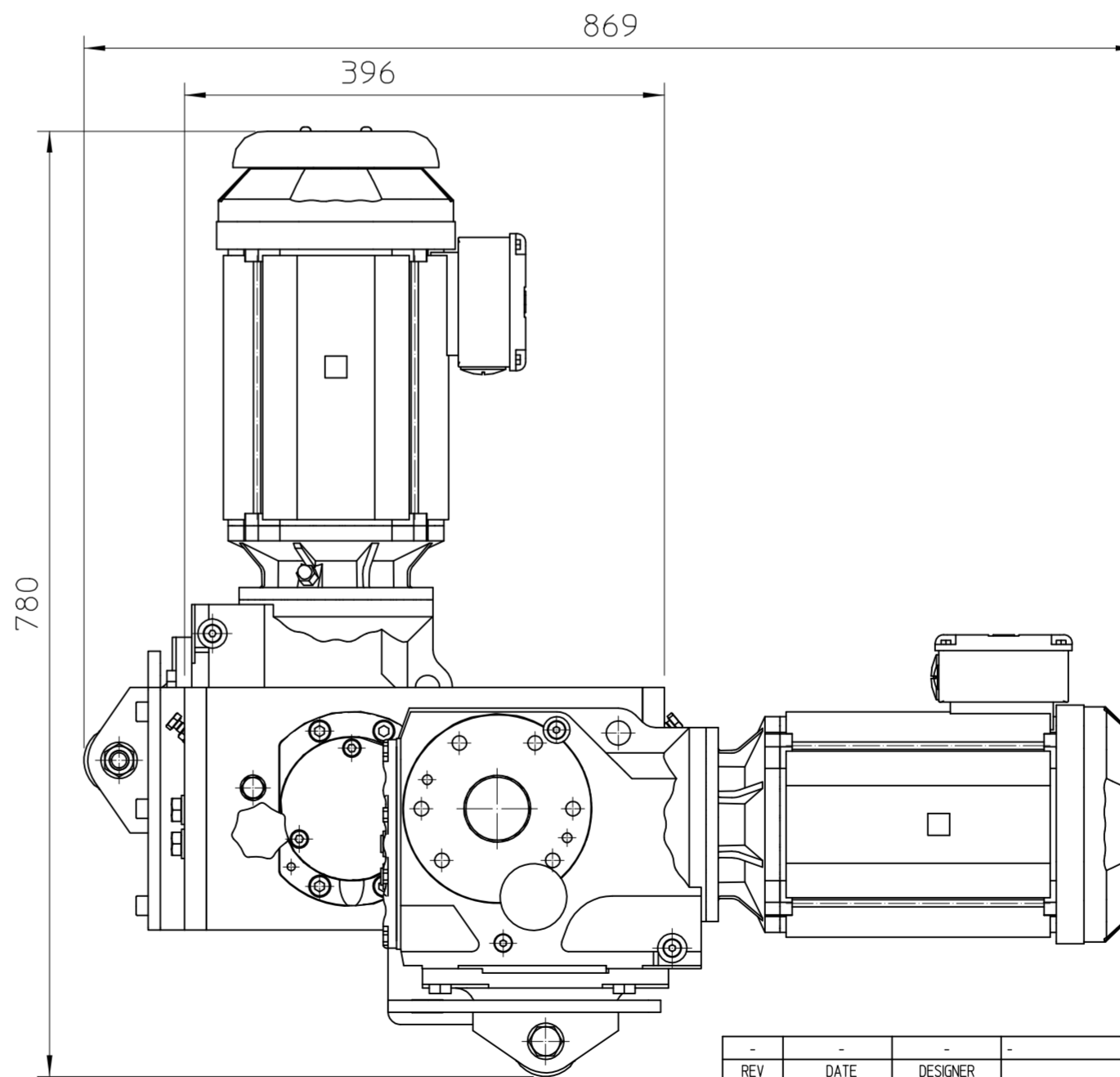

When no tol. stated use :		
0.5 -	3	+0.1
>	3 - 6	+0.1
>	6 - 30	+0.2
>	30 - 120	+0.3
>	120 - 400	+0.5
>	400 - 1000	+0.8
>	1000 - 2000	+1.2
>	2000 - 4000	+2.0
>	4000 - 12000	+4.0
>	12000 - 20000	+6.0

REV	DATE	DESIGNER	DESCRIPTION	ENG.APR.	MFG.APR.
Project: -			Customer name: -		
Title: Shredder STS-B26.03_US			Customer ref.no: -		
Subtitle: Dimension Drawing			Drawn by: WDV	Date: 12-06-2019	
			Status: DEF	Mass: N/A	
			Geometric tol. ISO 1101 Roughness tol. ISO 1302 General tol. ISO 2768-1 ISO 2768-2		Sheet 2 of 2 Scale 1:5 Size A2
			Project number -	Part number STS-B26.03_US	Rev. 0